

FX25 TRI

LOW PROFILE

25mm DIAMETER LOW PROFILE HEAD

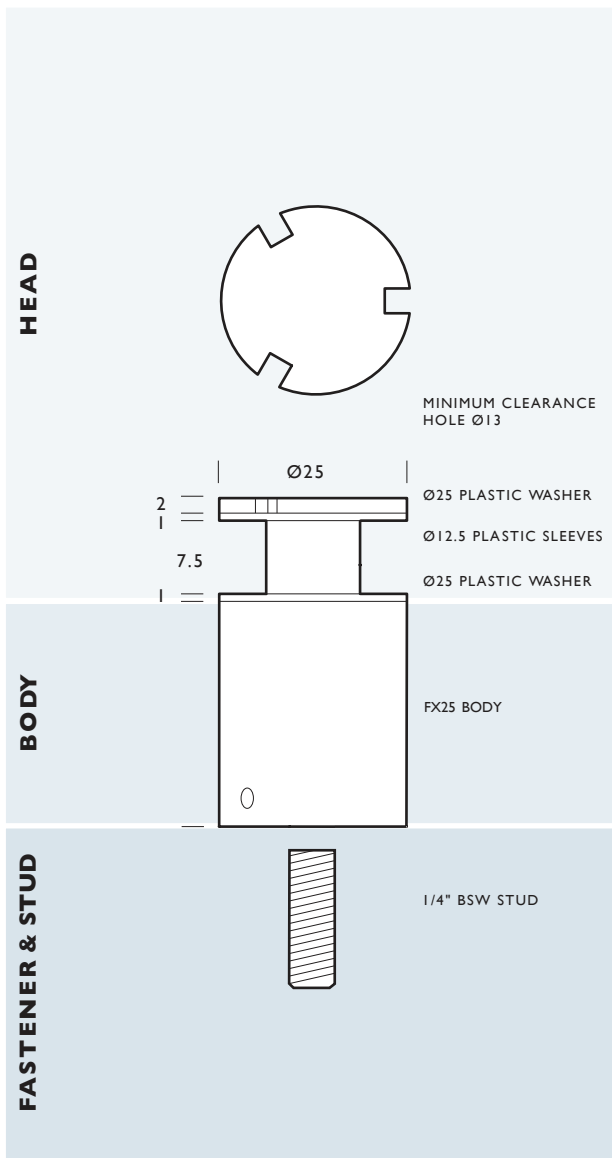

HEAD:



FX25 TRI HEAD PACK:

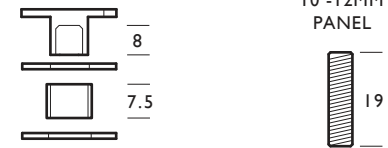

BODIES:

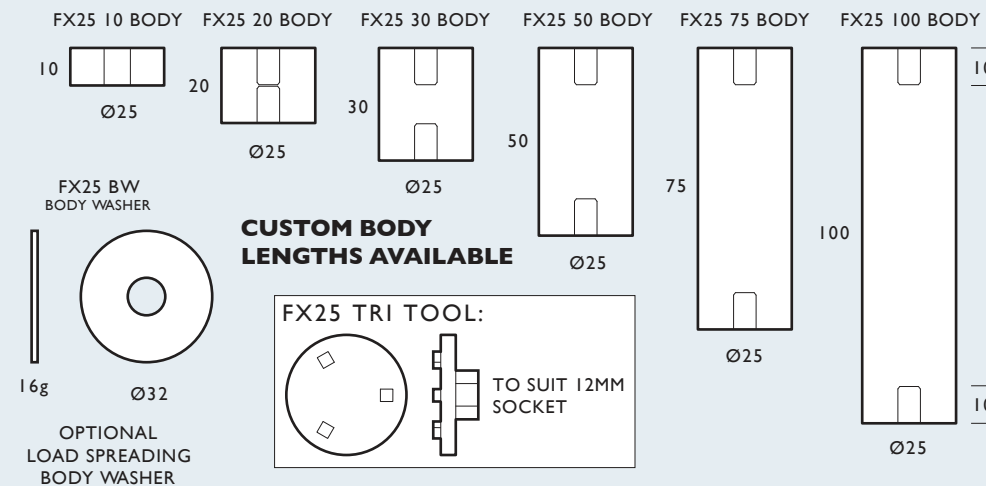

FASTENERS:

fasteners supplied with 1/4" bsw stud

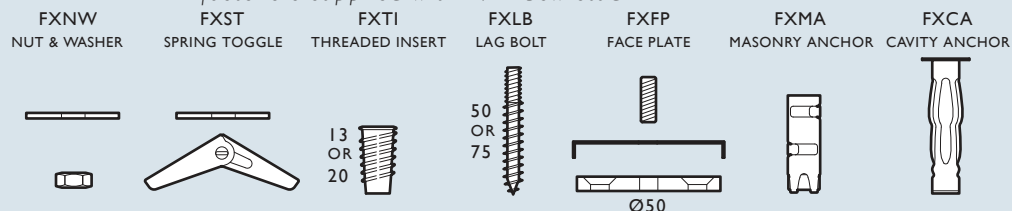

MATERIAL:

- 316 Grade Stainless Steel

PANEL THICKNESS:

Head Pack 10 - 12mm
Optional studs available:
19mm, 22mm, 25mm, 27mm, 29mm, 32mm, 38mm, 51mm, 75mm, 100mm

MINIMUM CLEARANCE HOLE:

With isolating sleeve Ø13
Without isolating sleeve Ø10

THREAD:

Head: 1/4" B.S.W x 8mm
Fastener: 1/4" B.S.W x 10mm

FINISH:

Satin Stainless Steel

LOCATION:

Interior and exterior applications

PRODUCT COMPLIANCY:

As FIX Systems are not certified engineers, it is the buyer's responsibility to ensure that the application of all FIX products is suitable for its intended use and that it is compliant with relevant safety standards.

