

25mm DIAMETER WIRE CLAMP ASSEMBLY

FX25 WCA

FX25 WCA - SINGLE CLAMP

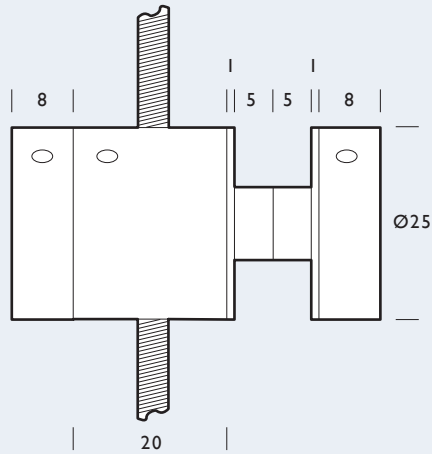

FX25 WCA SINGLE CLAMP PACK:

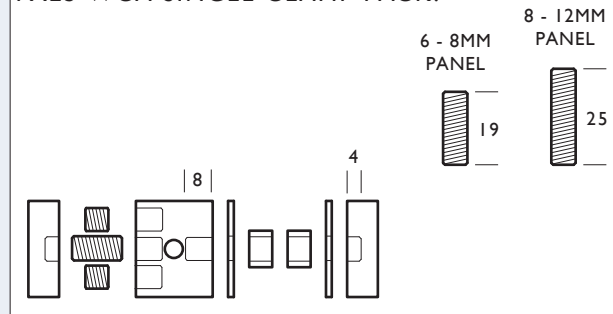

FX25 WCA - DOUBLE CLAMP

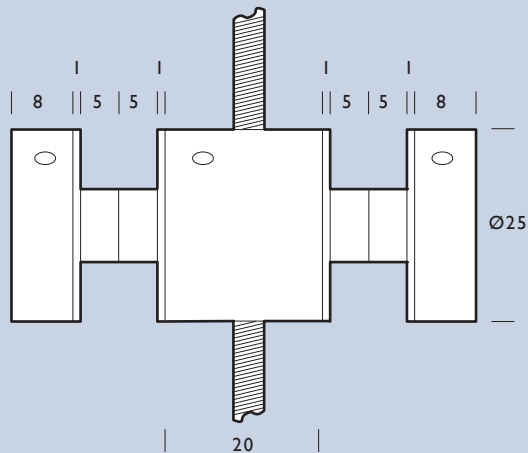

FX25 WCA DOUBLE CLAMP PACK:

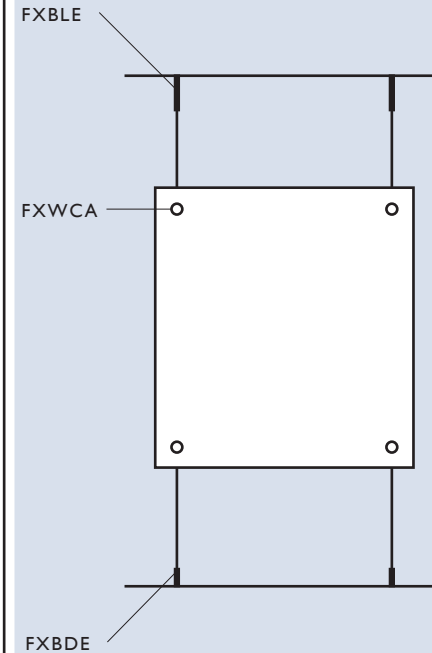
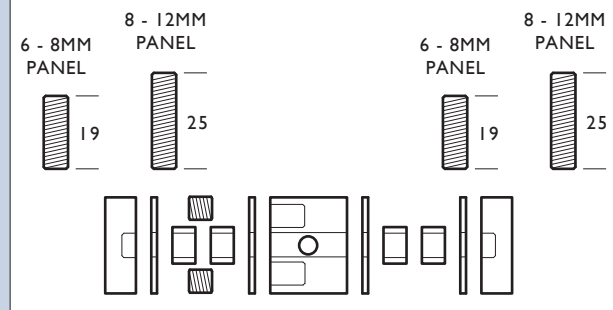

MATERIAL:

316 Grade Stainless Steel

PANEL THICKNESS:

Head Pack 6 - 12mm
Optional studs available:
19mm, 22mm, 25mm, 27mm, 29mm,
32mm, 38mm, 51mm, 75mm, 100mm

MINIMUM CLEARANCE HOLE:

With isolating sleeve $\varnothing 13$
Without isolating sleeve $\varnothing 17$

THREAD:

Head: 1/4" B.S.W x 4mm
Fastener: 1/4" B.S.W x 8mm

FINISH:

Satin Stainless Steel

LOCATION:

Interior and exterior applications

PRODUCT COMPLIANCY:

As FIX Systems are not certified engineers, it is the buyer's responsibility to ensure that the application of all FIX products is suitable for its intended use and that it is compliant with relevant safety standards.

FX19/25 TOOL:

