

FX19 PSF PANEL SCREW FIXING

19mm DIAMETER PANEL SCREW FIXING

HEAD:



FX19 PSF FIXING PACK:

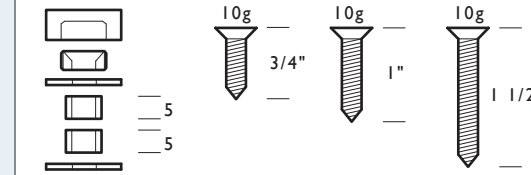

BODIES:

FX19 10 BODY



FASTENERS:

PLEASE NOMINATE REQUIRED SCREW LENGTH

- 1/4" B.S.W COUNTERSUNK MACHINE SCREWS
- 10g COUNTERSUNK SELF DRILLING SCREWS
- 10g COUNTERSUNK SELF TAPPING SCREWS

*VARIOUS LENGTHS AVAILABLE

MATERIAL:

316 Grade Stainless Steel

PANEL THICKNESS:

Head Pack 6 - 12mm glass
or 1-12mm other sheet materials.

*Can be used with any
10g countersunk self tapping,
self drilling or machine screw.*

MINIMUM CLEARANCE HOLE:

With isolating sleeve Ø9.5
Without isolating sleeve Ø7

SCREW:

10g countersunk screw

FINISH:

Satin Stainless Steel

LOCATION:

Interior and exterior applications

PRODUCT COMPLIANCY:

As FIX Systems are not certified engineers, it is the buyer's responsibility to ensure that the application of all FIX products is suitable for its intended use and that it is compliant with relevant safety standards.

FX TOOL:

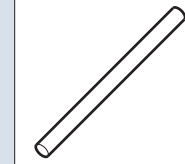

HEAD

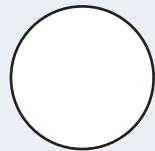

MINIMUM CLEARANCE
HOLE Ø10

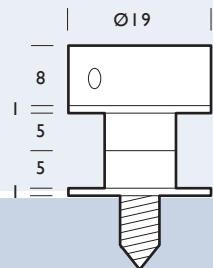

Ø19 PLASTIC WASHER
Ø9.5 PLASTIC SLEEVES
Ø19 PLASTIC WASHER

CSK SELF TAPPING
10g x 1"

FASTENER

